

DTC	B1782	Rear Occupant Classification Sensor LH Circuit Malfunction
------------	--------------	---

DESCRIPTION

The rear occupant classification sensor LH circuit consists of the occupant classification ECU and the rear occupant classification sensor LH.

DTC B1782 is recorded when a malfunction is detected in the rear occupant classification sensor LH circuit.

DTC No.	DTC Detecting Condition	Trouble Area
B1782	<ul style="list-style-type: none"> • Occupant classification ECU detects line short circuit signal, open circuit signal, short circuit to ground signal or short circuit to B+ signal in the rear occupant classification sensor LH circuit for 2 seconds • Rear occupant classification sensor LH malfunction • Occupant classification ECU malfunction 	<ul style="list-style-type: none"> • No. 1 seat wire • Front seat assembly RH (Rear occupant classification sensor LH) • Occupant classification ECU

RS

WIRING DIAGRAM

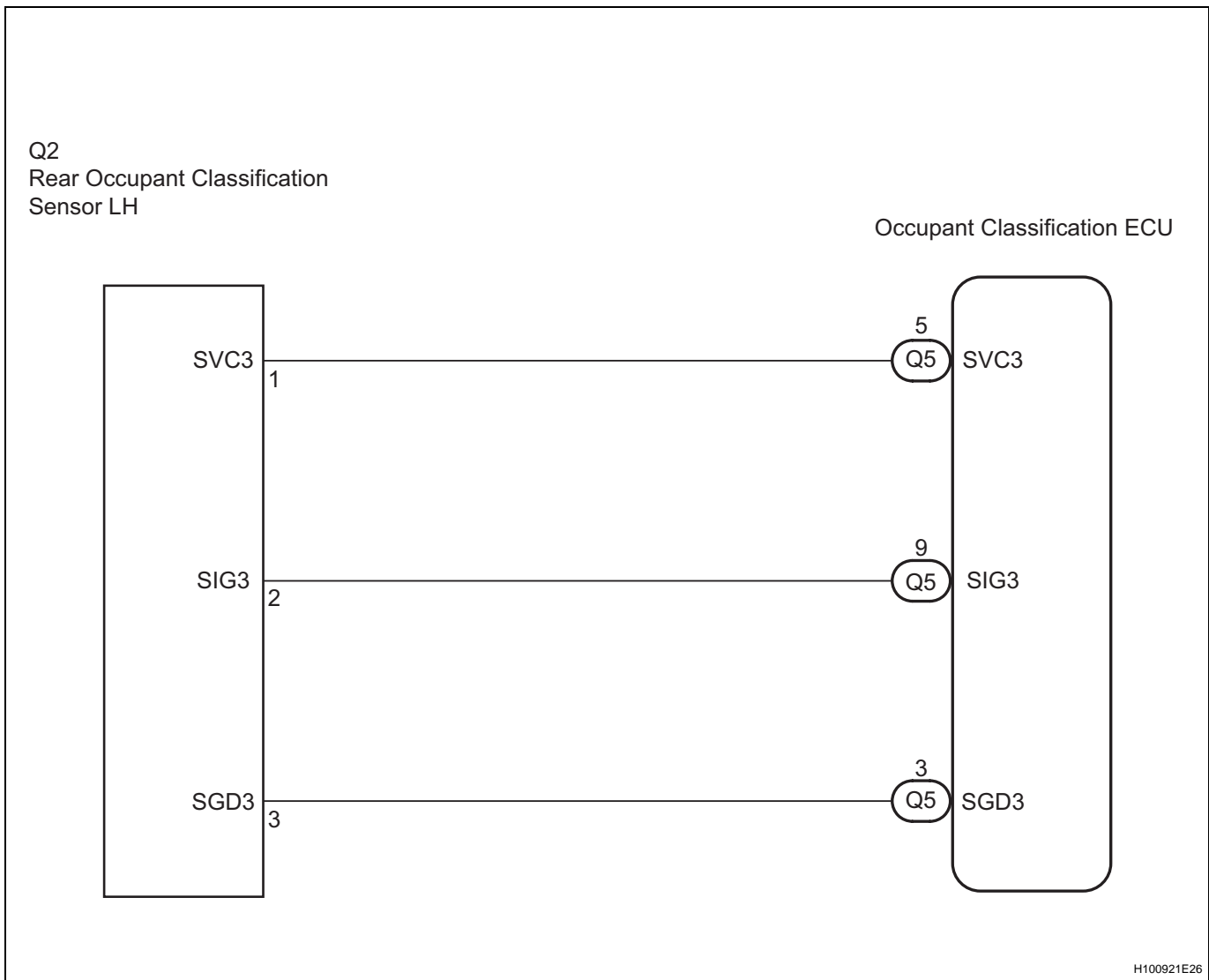

INSPECTION PROCEDURE

HINT:

- If troubleshooting (wire harness inspection) is difficult to perform, remove the front passenger seat installation bolts to see the under surface of the seat cushion.
- In the above case, hold the seat so that it does not tip over. Holding the seat for a long period of time may cause a problem, such as seat rail deformation. Hold the seat up only for as long as necessary.

1 CHECK DTC

- Turn the ignition switch to the on position.
- Clear the DTCs stored in the memory (See page [RS-254](#)).

HINT:

First clear DTCs stored in the occupant classification ECU and then in the center airbag sensor assembly.

- Turn the ignition switch to the lock position.
- Turn the ignition switch to the on position.
- Check the DTCs (See page [RS-254](#)).

OK:

DTC B1782 is not output.

HINT:

Codes other than DTC B1782 may be output at this time, but they are not related to this check.

OK

USE SIMULATION METHOD TO CHECK

NG

2 CHECK CONNECTION OF CONNECTORS

- Turn the ignition switch to the lock position.
- Disconnect the negative (-) terminal cable from the battery, and wait for at least 90 seconds.
- Check that the connectors are properly connected to the occupant classification ECU and the rear occupant classification sensor LH.

OK:

The connectors are properly connected.

NG

CONNECT CONNECTORS

OK

3 CHECK NO.1 SEAT WIRE (TO B+)

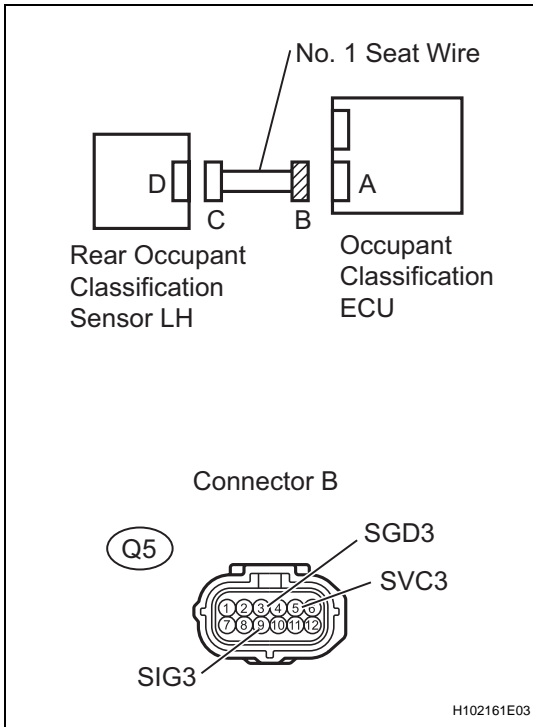

- (a) Disconnect the connectors from the occupant classification ECU and the rear occupant classification sensor LH.
- (b) Connect the negative (-) terminal cable to the battery.
- (c) Turn the ignition switch to the on position.
- (d) Measure the voltage.

Standard voltage

Tester connection	Condition	Specified condition
Q5-3 (SGD3) - Body ground	Ignition switch on	Below 1 V
Q5-5 (SVC3) - Body ground	Ignition switch on	Below 1 V
Q5-9 (SIG3) - Body ground	Ignition switch on	Below 1 V

OK

NG REPAIR OR REPLACE NO.1 SEAT WIRE

4 CHECK NO.1 SEAT WIRE (FOR OPEN)

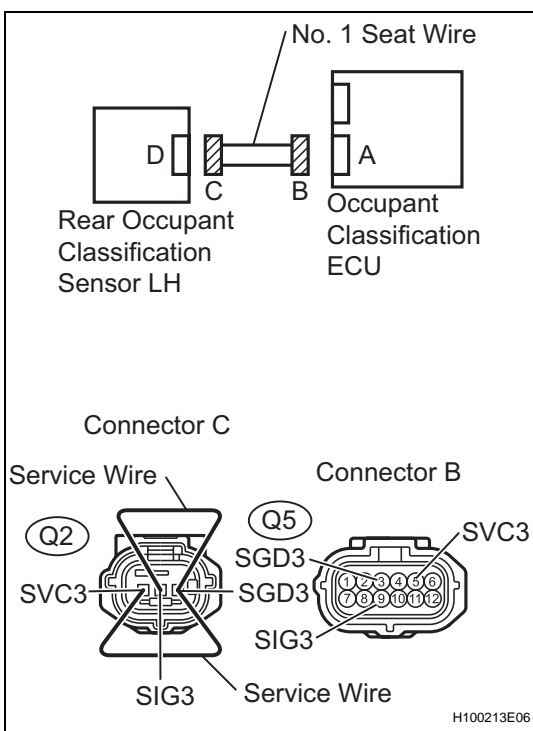

- (a) Turn the ignition switch to the lock position.
- (b) Disconnect the negative (-) terminal cable from the battery, and wait for at least 90 seconds.
- (c) Using a service wire, connect Q2-1 (SVC3) and Q2-3 (SGD3), and connect Q2-2 (SIG3) and Q2-3 (SGD3) of connector C.

NOTICE:

Do not forcibly insert a service wire into the terminals of the connector when connecting.

- (d) Measure the resistance.

Standard resistance

Tester connection	Condition	Specified condition
Q5-5 (SVC3) - Q5-3 (SGD3)	Always	Below 1 Ω
Q5-9 (SIG3) - Q5-3 (SGD3)	Always	Below 1 Ω

OK

NG REPAIR OR REPLACE NO.1 SEAT WIRE

RS

5 CHECK NO.1 SEAT WIRE (FOR SHORT)

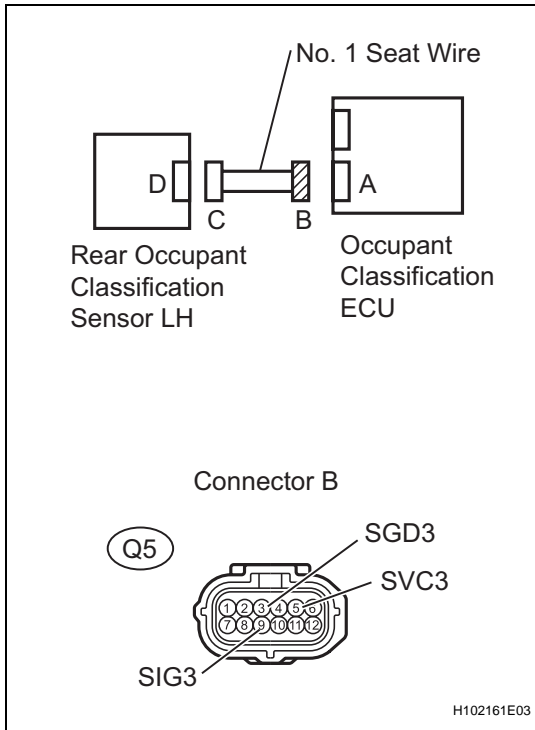

- (a) Disconnect the service wire from connector C.
- (b) Measure the resistance.

Standard resistance

Tester connection	Condition	Specified condition
Q5-5 (SVC3) - Q5-3 (SGD3)	Always	1 MΩ or higher
Q5-9 (SIG3) - Q5-3 (SGD3)	Always	1 MΩ or higher
Q5-5 (SVC3) - Q5-9 (SIG3)	Always	1 MΩ or higher

NG

REPAIR OR REPLACE NO.1 SEAT WIRE

RS

OK

6 CHECK NO.1 SEAT WIRE (TO GROUND)

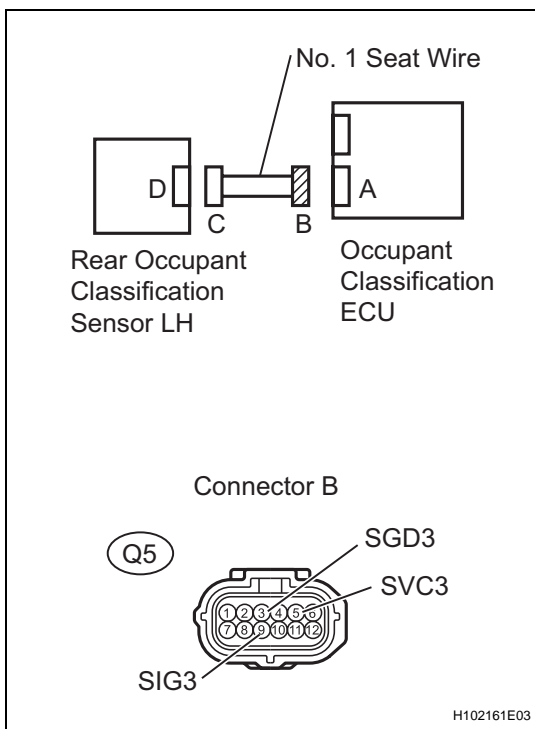

- (a) Measure the resistance.
- Standard resistance**

Tester connection	Condition	Specified condition
Q5-3 (SGD3) - Body ground	Always	1 MΩ or higher
Q5-5 (SVC3) - Body ground	Always	1 MΩ or higher
Q5-9 (SIG3) - Body ground	Always	1 MΩ or higher

NG

REPAIR OR REPLACE NO.1 SEAT WIRE

OK

7 CHECK DTC

- (a) Connect the connectors to the occupant classification ECU and the rear occupant classification sensor LH.
- (b) Connect the negative (-) terminal cable to the battery.
- (c) Turn the ignition switch to the on position.
- (d) Clear the DTCs stored in the memory (See page [RS-254](#)).

HINT:

First clear DTCs stored in the occupant classification ECU and then in the center airbag sensor assembly.

- (e) Turn the ignition switch to the lock position.
- (f) Turn the ignition switch to the on position.
- (g) Check the DTCs (See page [RS-254](#)).

OK:

DTC B1782 is not output.

HINT:

Codes other than DTC B1782 may be output at this time, but they are not related to this check.

OK**USE SIMULATION METHOD TO CHECK****NG****8 REPLACE OCCUPANT CLASSIFICATION ECU**

- (a) Turn the ignition switch to the lock position.
- (b) Disconnect the negative (-) terminal cable from the battery, and wait for at least 90 seconds.
- (c) Replace the occupant classification ECU (See page [RS-412](#)).

HINT:

Perform the inspection using parts from a normal vehicle if possible.

NEXT**9 PERFORM ZERO POINT CALIBRATION**

- (a) Connect the negative (-) terminal cable to the battery.
- (b) Connect the intelligent tester to the DLC3.
- (c) Turn the ignition switch to the on position.
- (d) Using the intelligent tester, perform the zero point calibration (See page [RS-246](#)).

OK:

COMPLETED is displayed.

NG**Go to step 12****OK****RS**

10 PERFORM SENSITIVITY CHECK

- (a) Using the intelligent tester, perform the sensitivity check (See page [RS-246](#)).
- (1) Confirm that nothing is placed on the passenger seat.
 - (2) Confirm that the beginning sensor reading is within the standard range.
Standard range:
-3.2 to 3.2 kg (-7 to 7 lb)
 - (3) Place a 30 kg (66.14 lb) weight (e.g. a lead mass) onto the front passenger seat.
 - (4) Confirm that the sensitivity is within the standard range.
Standard range:
27 to 33 kg (59.52 to 72.75 lb)
- HINT:
When performing the sensitivity check, use a solid metal weight (the check result may not be accurate if a liquid weight is used).

NG

Go to step 12

OK

11 CHECK DTC

- (a) Connect the negative (-) terminal cable to the battery.
 - (b) Turn the ignition switch to the on position.
 - (c) Clear the DTCs stored in the memory (See page [RS-254](#)).
HINT:
First clear DTCs stored in the occupant classification ECU and then in the center airbag sensor assembly.
 - (d) Turn the ignition switch to the lock position.
 - (e) Turn the ignition switch to the on position.
 - (f) Check the DTCs (See page [RS-254](#)).
- OK:**
DTC B1782 is not output.
- HINT:
Codes other than DTC B1782 may be output at this time, but they are not related to this check.

OK

END

NG

12 REPLACE FRONT SEAT ASSEMBLY RH

- (a) Turn the ignition switch to the lock position.
- (b) Disconnect the negative (-) terminal cable from the battery, and wait for at least 90 seconds.
- (c) Replace the front seat assembly RH (See page [SE-5](#)).

NEXT

13 | **PERFORM ZERO POINT CALIBRATION**

- (a) Connect the negative (-) terminal cable to the battery.
- (b) Connect the intelligent tester to the DLC3.
- (c) Turn the ignition switch to the on position.
- (d) Using the intelligent tester, perform the zero point calibration (See page [RS-246](#)).

OK:**COMPLETED** is displayed.

NEXT

14 | **PERFORM SENSITIVITY CHECK**

- (a) Using the intelligent tester, perform the sensitivity check (See page [RS-246](#)).
 - (1) Confirm that nothing is placed on the passenger seat.
 - (2) Confirm that the beginning sensor reading is within the standard range.
Standard range:
-3.2 to 3.2 kg (-7 to 7 lb)
 - (3) Place a 30 kg (66.14 lb) weight (e.g. a lead mass) onto the front passenger seat.
 - (4) Confirm that the sensitivity is within the standard range.

Standard range:**27 to 33 kg (59.52 to 72.75 lb)****HINT:**

When performing the sensitivity check, use a solid metal weight (the check result may not be accurate if a liquid weight is used).

NEXT

RS**END**